

# **AT680** Leakage Current/IR Meter User's Manual



Address: 7BC, No.91, Guanhe(W) Rd,  
Changzhou,  
Jiangsu,  
China (PRC)

Post Code: 213002

Telephone (Sales): 0086-0519-88805550 / 88050005 Ext 0  
Telephone (Tech.): 0086-0519-88805550 / 88050005 Ext 8008

Fax: 0086-0519-88050008

<http://www.applent.com>

Sales Email: [sales@applent.com](mailto:sales@applent.com)

Tech Email: [tech@applent.com](mailto:tech@applent.com)

©2005~2009 Applent Instruments, Inc.

---

The material in this manual is for informational purposes only and is subject to change, without notice. Applent assumes no responsibility for any error or for consequential damages that may result from the misinterpretation of any procedures in this publication.

This document contains proprietary information which is protected by copyright.

All rights are reserved.

No part of this document may be photocopied, reproduced, or translated to another language without the prior written consent of the Applent Instruments Inc.

# Safety Summary

## **Warning** **Dangerous:**

When you notice any of the unusual conditions listed below, immediately terminate operation and disconnect the power cable.

Please Contact Applent Instruments Incorporation sales representative for repair of the instrument. If you continue to operate without repairing the instrument, there is a potential fire or shock hazard for the operator.

- Instrument operates abnormally
- Instrument emits abnormal noise, smell, smoke or a spark-like light during the operation.
- Instrument generates high temperature or electrical shock during operation.
- Power cable, plug, or receptacle on instrument is damaged.
- Foreign substance or liquid has fallen into the instrument.

# Safety Summary

## **Warning** **Dangerous:**

The following general safety precautions must be observed during all phases of operation, service, and repair of this instrument. Failure to comply with these precautions or with specific WARNINGS elsewhere in this manual may impair the protection provided by the equipment. In addition it violates safety standards of design, manufacture, and intended use of the instrument.

---

Disclaimer *The Applent Instruments assumes no liability for the customer's failure to comply with these requirements.*

---

Ground  
The Instrument To avoid electric shock hazard, the instrument chassis and cabinet must be connected to a safety earth ground by the supplied power cable with earth blade.

DO NOT  
Operate In An Explosive  
Atmosphere Do not operate the instrument in the presence of inflammable gasses or fumes. Operation of any electrical instrument in such an environment constitutes a definite safety hazard.

Keep Away  
From Live  
Circuits Operating personnel must not remove instrument covers. Component replacement and internal adjustments must be made by qualified maintenance personnel. Do not replace components with the power cable connected. Under certain conditions, dangerous voltages may exist even with the power cable removed. To avoid injuries, always disconnect power and discharge circuits before touching them.

DO NOT  
Service Or Adjust Alone Do not attempt internal service or adjustment unless another person, capable of rendering first aid and resuscitation, is present.

DO NOT  
Substitute Parts Or  
Modify Instrument Because of the danger of introducing additional hazards, do not install substitute parts or perform unauthorized modifications to the instrument. Return the instrument to an Applent Inc Sales and Service Office for service and repair to ensure that safety features are maintained.

  
WARNING & DANGEROUS

---

**Dangerous voltage levels, capable of causing death, are present in this instrument.**

**Use extreme caution when handling, testing, and adjusting this instrument.**

---

AT680 Leakage Current/IR Meter

# **User's Manual**

English

 **Applent Instruments, Inc.**

©2005-2009 Applent Instruments, Inc.

## CERTIFICATION, LIMITED WARRANTY & LIMITATION OF LIABILITY

**Applent Instruments, Inc.** (shortened form **Applent**) certifies that this product met its published specifications at the time of shipment from the factory. Applent further certifies that its calibration measurements are traceable to the People's Republic of China National Institute of Standards and Technology, to the extent allowed by the Institution's calibration facility or by the calibration facilities of other International Standards Organization members.

This Applent instrument product is warranted against defects in material and workmanship for a period corresponding to the individual warranty periods of its component products. **The warranty period is 2 years and begins on the date of shipment.** During the warranty period, Applent will, at its option, either repair or replace products that prove to be defective. This warranty extends only to the original buyer or end-user customer of a Applent authorized reseller, and does not apply to fuses, disposable batteries or to any product which, in Applent's opinion, has been misused, altered, neglected or damaged by accident or abnormal conditions of operation or handling.

For warranty service or repair, this product must be returned to a service facility designated by Applent. The buyer shall prepay shipping charges to Applent and Applent shall pay shipping charges to return the product to the Buyer. However, the Buyer shall pay all shipping charges, duties, and taxes for products returned to Applent from another country.

Applent warrants that its software and firmware designated by Applent for use with an instrument will execute its programming instruction when properly installed on that instrument. Applent does not warrant that the operation of the instrument, or software, or firmware, will be uninterrupted or error free.

The foregoing warranty shall not apply to defects resulting from improper or inadequate maintenance by the Buyer, Buyer-supplied software or interfacing, unauthorized modification or misuse, operation outside the environmental specifications for the product, or improper site preparation or maintenance.

THIS WARRANTY IS BUYER'S SOLE AND EXCLUSIVE REMEDY AND IS IN LIEU OF ALL OTHER WARRANTIES, EXPRESS OR IMPLIED, INCLUDING BUT NOT LIMITED TO ANY IMPLIED WARRANTY OF MERCHANTABILITY OR FITNESS FOR A PARTICULAR PURPOSE. APPLMENT SHALL NOT BE LIABLE FOR ANY SPECIAL, INDIRECT, INCIDENTAL OR CONSEQUENTIAL DAMAGES OR LOSSES, INCLUDING LOSS OF DATA, WHETHER ARISING FROM BREACH OF WARRANTY OR BASED ON CONTRACT, TORT, RELIANCE OR ANY OTHER THEORY.

Applent Instruments, Inc.  
Changzhou,  
Jiangsu,  
The People's Republic of China.  
Rev.A2 January, 2005  
Rev.B0 January, 2008

# Contents

Safety Summary .....	2
Safety Summary .....	3
CERTIFICATION, LIMITED WARRANTY & LIMITATION OF LIABILITY .....	5
1 Unpacking and Preparation .....	8
1.1 Incoming Inspection .....	8
1.2 Power Supply .....	8
1.3 Setting up Fuse .....	9
1.4 Environmental Requirements .....	9
1.5 Cleaning .....	9
1.6 How to Remove the Handle .....	9
2 Overview .....	11
2.1 Introduction .....	11
2.2 Model Numbers Contrast .....	11
2.3 Main Specifications .....	11
2.4 Feature overview .....	12
3 Getting Started .....	13
3.1 Front Panel .....	13
3.1.1 Front Panel Summary .....	13
3.1.3 Keypad .....	15
3.2 Real Panel Summary .....	16
3.3 Power-up .....	17
3.4 Measurement configuration .....	17
3.4.1 Connection to Device under Test (DUT) .....	17
3.4.2 Voltage .....	18
3.4.3 Range .....	18
3.4.4 Charge Timer .....	19
3.4.5 Sample Timer .....	19
3.4.6 Clear Zero Correction (Zeroing) .....	20
3.4.7 Adjust VFD Brightness .....	20
3.5 Measurement Procedure .....	20
3.5.1 Charge – Test - Discharge .....	20
3.5.2 Changing the Parameter .....	21
3.5.3 Rate .....	21
3.5.4 Display IR and Leakage at one time .....	22
3.5.5 Display Peak .....	22
3.5.6 Sorting Result displays at 2nd line .....	23
3.5.7 Turning ON/OFF the Beep Feature .....	23
3.5.8 Set Trigger ( Trigger <sup>Shift</sup> ) .....	24
3.5.9 Remote .....	24
4 Comparator .....	26
4.1 Input Limit reference value .....	26
4.2 Set Beep Feature: .....	26
4.2.1 Turning on/off the beep : .....	26
4.2.2 Set Beep : .....	26
4.2.3 How the comparator work .....	27
5 Handler Interface .....	28
5.1 Pin Assignment .....	28
5.2 Electrical Characteristics .....	30
5.3 Timing Chart .....	31
6 Remote Control .....	33
6.1 About RS-232C .....	33
6.2 Enable RS-232C Interface and select baud rate .....	34
6.3 SCPI Language .....	34
7 Command Reference .....	35
7.1 Terminator .....	35
7.2 Notation Conventions and Definitions .....	35

<b>7.3 Command Structure</b> .....	35
<b>7.4 Header and Parameters</b> .....	37
<b>7.5 Command Reference</b> .....	38
<b>7.6 Function Subsystem</b> .....	39
:RESistance.....	39
:CURRent .....	39
:RANGe.....	39
:RANGe:AUTO .....	40
<b>7.7 VOLTage Subsystem</b> .....	40
<b>7.8 CORRection Subsystem</b> .....	41
<b>7.9 COMPArator Subsystem</b> .....	41
:RECOrd.....	42
:RESistance.....	42
:CURRent .....	42
:BEEP .....	42
:BEEP:SET .....	43
<b>7.10 STATE Subsystem</b> .....	43
:CHARge .....	44
:DISCharge .....	44
<b>7.11 TIMEr Subsystem</b> .....	44
:CHARge.....	44
:SAMPle .....	45
<b>7.12 APERTure Subsystem</b> .....	45
<b>7.13 SYSTEm Subsystem</b> .....	45
:KEYLock.....	46
<b>7.14 TRIGger Subsystem</b> .....	46
[:IMMediate] .....	46
:SOURce.....	46
<b>7.15 FETCh Subsystem</b> .....	47
FETCh?.....	47
<b>7.16 ERRor Subsystem</b> .....	47
ERRor? .....	47
<b>7.17 *IDN? Common Command</b> .....	48
<b>7.18 *RST Common Command</b> .....	48
<b>A Specifications</b> .....	49
<b>AT680 Leakage Current/IR Meter Specifications</b> .....	49
<b>Dimensions</b> .....	51

# 1 Unpacking and Preparation



This chapter describes how to set up and start the AT680 Leakage Current/IR Meter

- Incoming Inspection
- Power Requirements
- Setting up the Fuse
- Environmental Requirements
- Cleaning
- How to Remove the Handle

## 1.1 Incoming Inspection

After you receive the instrument, carry out checks during unpacking according to the following procedure.

1. Check that the packing box or shock-absorbing material used to package the instrument has not been damaged.
2. Referring to Table 1-1, check that all packaged items supplied with the meter have been provided as per the specified options.

Table 1-1 **Items Packaged with the meter**

Name	Qty	Remark
User's Manual	1	
Power Cable	1	220V/50Hz
Fuse	2	250V, 1A Slow-blow
ATL680 Test Clip Leads	1	
Warranty certificate	1	Includes Product certification

## 1.2 Power Supply

Confirm that the power supplied to the AT680 meets the following requirements:

Voltage: 100-120VAC  
 Frequency: 47.5-52.5Hz  
 Power-consumption: 50VA max



**WARNING:** The ground wire should be earthed to avoid being electric shock.  
 If you change the power cord, make sure the ground wire earthed.



## 1.3 Setting up Fuse

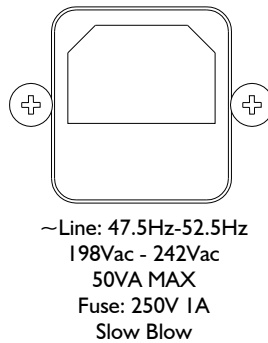

Figure 1-1 Fuse Holder



---

Please use the following fuse type:  
**UL/CSA type, Slow-Blow, 5×20-mm miniature fuse, 1A, 250 V.**

---

## 1.4 Environmental Requirements

Ensure that the operating environment meets the following requirements.

Temperature: 0°C to 55°C

Operating stated accuracy: <80%RH

Temperature range at calibration: 23°C±5°C

Stated accuracy: <70%RH

## 1.5 Cleaning

To prevent electrical shock, disconnect the AT680 power cable from the receptacle before cleaning.

Use a dry cloth or a cloth slightly dipped in water to clean the casing.

Do not attempt to clean the AT680 internally.



---

**WARNING:** Don't Use Organic Solvents (such as alcohol or gasoline) to clean the Instrument.

---

## 1.6 How to Remove the Handle

A handle kit is attached to the AT680.

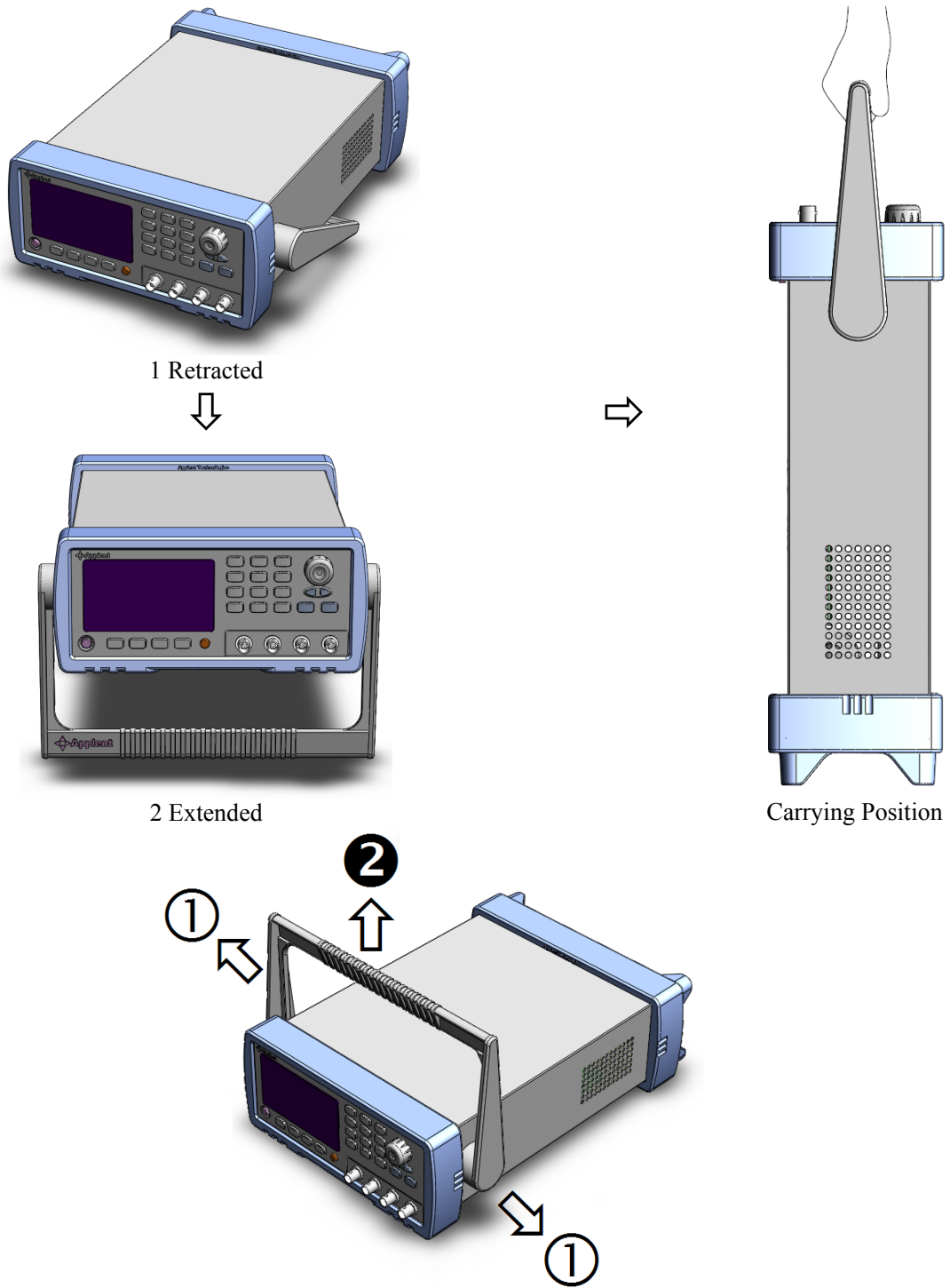

Remove Handle (Lift the handle perpendicular to the unit while pulling it in the direction of ①.)

Figure 1-2 Handle

# 2 Overview

---

The information is organized as follows

- Introduction
  - Main Specifications
  - Feature overview
- 

## 2.1 Introduction

Thank you for purchasing AT680 Leakage Current/IR Meter.

The Applent AT680 is a Leakage Current and Insulation Resistance Meter for quality control and laboratory use. AT680 is used for measuring insulation resistance and leakage current of electronic components, devices, dielectric materials, wires, cables and etc.

The AT680 Dual Display (insulation resistance and leakage current) Megohmmeter includes 4-digit (9,999 counts), 7-range (auto and manual), broad measurement range (1nA~20mA) and super fast test rate (55 readings per second). The voltage applied to the device under test (DUT) is programmable from 1 to 650 volts.

The AT680 can output comparison/decision results for sorting components into 2 bins. Furthermore, by using the handler interface, the AT680 can be easily combined with a component handler and a system controller to fully automate component testing, sorting, and quality-control data processing. A GD/NG indicator on VFD provides a visual display of test results based on a preset limit. Thirty sets of test conditions are stored in the unit and can be reprogrammed by the user.

The RS232C (used SCPI) and Handler interfaces are standard interfaces on the AT680 and enabled automatic testing.

## 2.2 Model Numbers Contrast

Model	Measurement range	Rate	Basic Accuracy
Standard: AT680	1nA-20mA	55times/s	±1%
Reduced: AT680SE	10nA-20mA	3 times/s	±2%

## 2.3 Main Specifications

Some main specifications of the AT680 include:



---

Full 680 specifications are included in Appendix A.

---

- Measuring Insulation Resistance and Leakage Current.
- Output Negative Voltage: 1.0VDC~650VDC, Basic Accuracy: 0.5%  
<100V: 0.1V step , ≥100V: 1V step.
- Leakage Current *Measurement Range*: 1nA-20mA
- Leakage Current Basic Accuracy: 1%
- Insulation Resistance *Measurement Range*: 1kΩ-325G

- Insulation Resistance Basic Accuracy: <10G:3%, ≥ 10G: 5%, ≥100G: 10%
- Max Charge Current: 200mA ± 20mA
- Automatic Test with 7 Ranges and Manual
- Test Rate
  - Slow: 3 readings/second with 9,999 counts*
  - Medium: 25 readings/second with 1,999 counts*
  - Fast: 55 readings/second with 1,999 counts*
- Built-in 2 timers
  - Charge Timer: 0s~999.9s*
  - Sample Timer: 0s~999.9s*
- Trigger mode:
  - Internal Trig, Manual (Remote) Trig and External (Handler) Trig.*

## 2.4 Feature overview

- High brightness VFD
  - window size: 98mm×58mm*
- Correction (Zeroing) Function
  - Zero out test lead and fixture measurement errors.*
- Built-in Comparator (Sorting)
  - Thirty sets of Record can be used to store user's data. Display on VFD Screen and/or Output to Handler.*
- Beep and VFD Brightness can be Adjusted
  - Setup GD or NG Beep and adjust VFD Brightness.*
- Interfaces
  1. Handler interface: GD/NG Output, Trig Signal Input and EOC (Busy) Output.
  2. RS232C interface: SCPI Compatibility, ASCII Transmission.

# 3 Getting Started



This chapter describes names and functions of the front panel, rear panel, and screen display and provides the basic procedures for operating AT680.

- Front Panel Summary
- Real Panel Summary
- Power-up
- Begin Measuring

## 3.1 Front Panel

### 3.1.1 Front Panel Summary

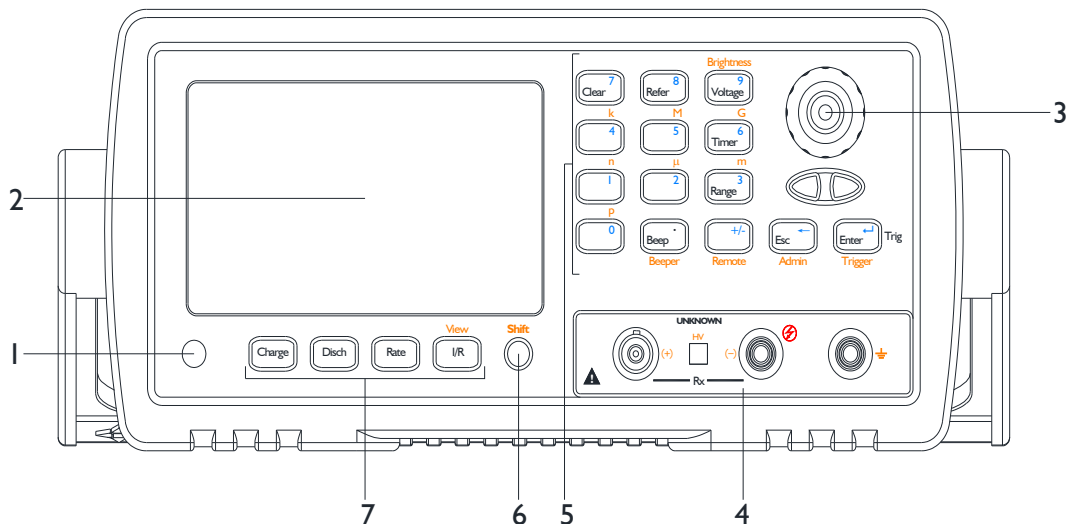

Figure 3-1 Front Panel

NO.	Function
1	<b>Power Switch</b> <i>To apply power to the instrument, Push Down: ON, Push Up: OFF</i>
2	<b>Display</b> <i>VFD Screen, Displays measurement results, instrument status and user's interface menus.</i> Full VFD Content Includes in figure "3-2 VFD" .
3	<b>Knob</b> <i>To Choose Menu Item and Input Number</i>
4	<b>Terminals</b> + <i>BNC (Red) (Sense)</i> - <i>High Negative Voltage Output (Black) (Drive)</i> GND <i>Ground (Red) (Ground Terminal for jumper of (+) Input Terminal or Guard Input to Chassis GND)</i> GND <i>earthing grip (If the measured piece is cable and capacitor, it doesn't have to be linked to earth, others should be screened.)</i> Full Terminals Information refers to "Connection to DUT"

5	<p><b>Keypad II (shifted or un-shifted)</b>                  Multi-function keys: Numeric, 1<sup>st</sup> Function and 2<sup>nd</sup> Function.                  Full Keypad Descript in follow section “3.1.3 Keypad”</p>
6	<p><b>Keypad I (shifted or un-shifted)</b>                  Dual-Function keys: 1<sup>st</sup> Function and 2<sup>nd</sup> Function.</p>

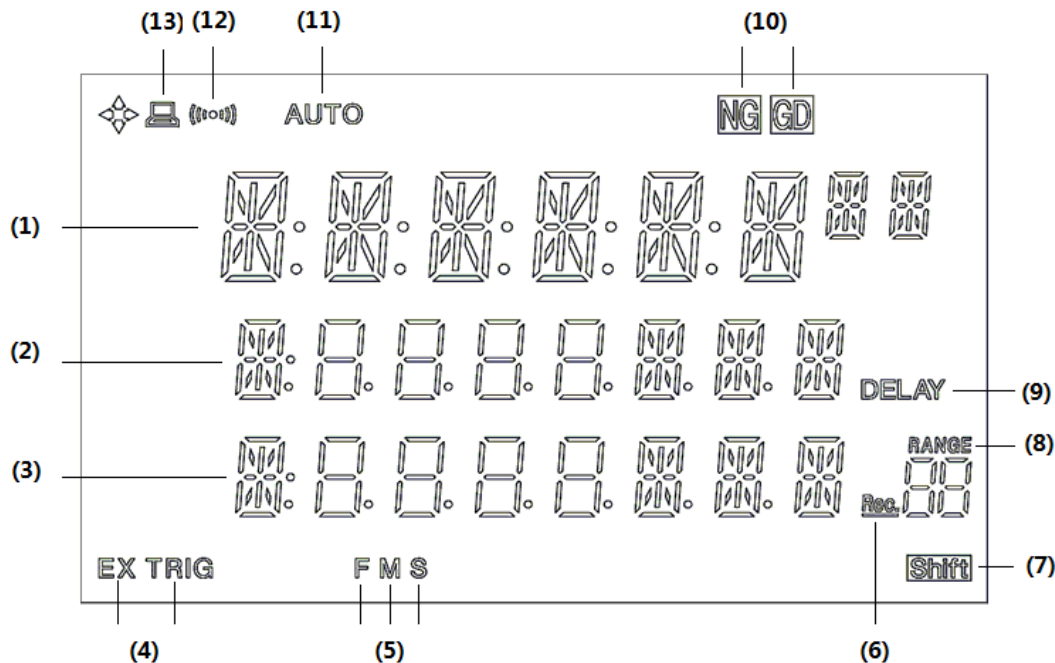

Figure 3-2 Displayer

NO.	Icon	Function
(1)	Digit Bit x8	1 <sup>st</sup> line displays “Dish” in the discharge state or display the measurement Results in the charge state.
(2)	Digit Bit x8	2 <sup>nd</sup> line displays sort results in the discharge state and displays the sorting results and second parameters in the charge state.
(3)	Digit Bit x8	3 <sup>rd</sup> line displays the output voltage.
(4)	EX TRIG	TRIG: Manual (Remote) Trigger enabled. EX TRIG: External Trigger enabled. Full Trigger Descript in follow section “3.5.8 Set Trigger”
(5)	FMS	Rate (Fast, Medium and Slow) Full Rate Descript in follow section “3.5.3 Rate”
(6)		Current Range Number or Record Number.
(8)		
(7)		Shifted to the 2 <sup>nd</sup> Function.
(9)	DELAY	Timer Started.
(10)	NG GD	NG: Fail., GD: Pass.
(11)	AUTO	Auto ranging enabled. Full Auto Descript in follow section “3.4.3 Range”
(12)		Beep Enabled. Full Beep Descript in follow section “3.5.7 Turn on/off the Beep feature”.
(13)		Remote Interface (RS232) ON. Full Remote Descript in follow section “3.5.9 Remote”

### 3.1.3 Keypad

ASSUMER : 

On the Instrument Panel:

**Black** Words on Button represents 1<sup>st</sup> Function ;

**Orange** Words on Panel represents 2<sup>nd</sup> Function ;

**Blue** Words on Button represents Numeric Key.



Figure 3-3 Keypad I

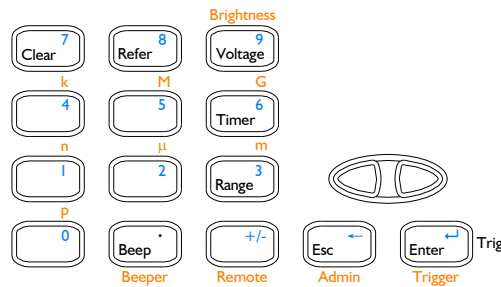

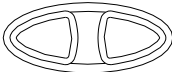



Figure 3-4 Keypad II

#### 1. 1<sup>st</sup> Function Keys (Un-shifted)

KEYPAD	Function
ASSUMER :  <b>Black</b> Words on Button represents 1 <sup>st</sup> Function ; Following functions can be chosen while the <b>Shift</b> mark on VFD is off.	
<b>Charge</b>	Charge/Measure Initiate the Measurement
<b>Disch</b>	Discharge the energy components (such as capacitances) to stop the measurement (terminate high voltage at the negative output terminals).
<b>Rate</b>	Measurement rate: 3 items could be chosen: <u>S</u> low, <u>M</u> edium, <u>F</u> ast
<b>Param</b>	Select the Parameter: <i>IR or Current</i>
<b>Clear</b>	Open Correction
<b>Refer</b>	Limit Reference Values
<b>Voltage</b>	Input the output Voltage values
<b>Timer</b>	Preset Charge Timer and Sample Timer.
<b>Range</b>	Auto or Manual measurement. Logo <b>AUTO</b> on VFD reps. Range Automatic
	Choose Range 1~7.
<b>Esc</b>	To exit menu mode with no parameter changes made and backspace one number. Available only in the Menu windows.
<b>Enter</b>	To switch user to entry mode and accept menu entry as entered. Available in the Menu windows.
<b>Trig</b>	Triggers a measurement from the front panel.

	Available in the Manual Trigger mode.
--	---------------------------------------

### 2. 2<sup>nd</sup> Functions (Shifted)

KEYPAD	Function
ASSUMER : 	On the Instrument Panel: <span style="background-color: orange;">Orange</span> Words on Panel represents 2 <sup>nd</sup> Function; Following functions can be chosen while the <span style="border: 1px solid black; padding: 2px;">Shift</span> mark on VFD is on.
<span style="border: 1px solid black; padding: 2px;">View</span>	The second line displays sorting results, second parameters (Resistance value and current value), maximum and minimum. A parameter's change each time that the key is pressed.
<span style="border: 1px solid black; padding: 2px;">Brightness</span>	Adjust VFD Brightness
n,μ,m,k,M,G	Unit Available in Input box.
Beeper	To setup the beep feature.
Remote	Open/Close RS232 Interface.
Admin	Only administrators can operate.
Trigger	Setting Trigger.

### 3. Numeric Keys

ASSUMER : 

On the Instrument Panel:

Blue Words on Button represents Numeric Key.

The numeric keys include Blue word keys, ESC key, Enter key and units (p, n, μ,m, k, M, G).

## 3.2 Real Panel Summary

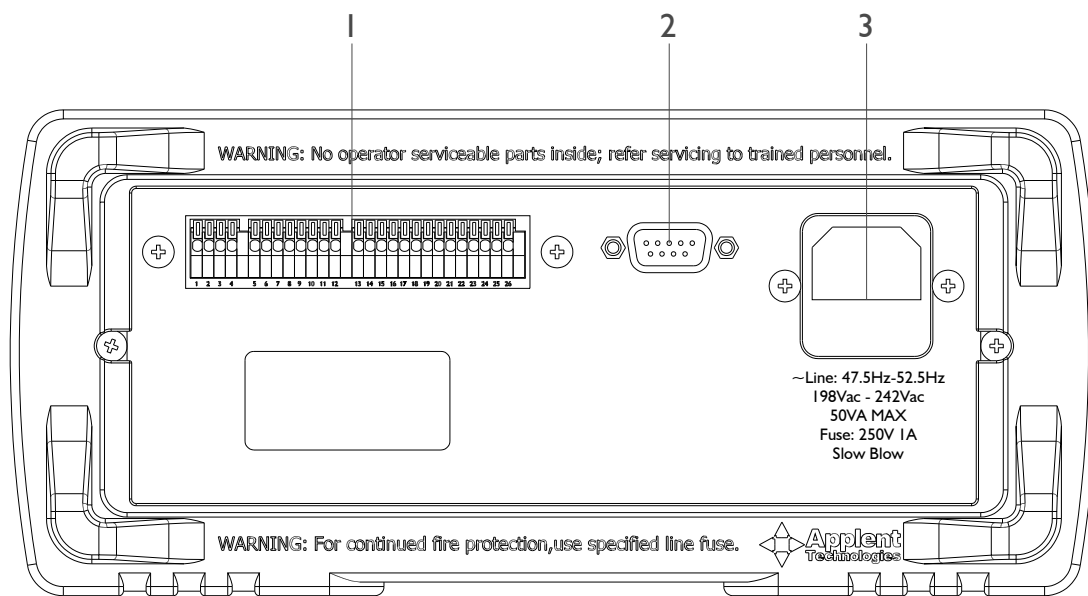

Figure 3-5 Real Panel



1. Handler Interface
2. RS232C Interface
3. AC Inlet Module

## 3.3 Power-up

### 3.3.1 Line Power Connection

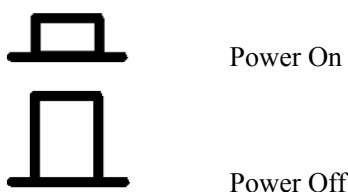

### 3.3.2 Power-up Sequence

On power-up, AT680 performs self-tests on its FlashRom, RAM and momentarily lights all segments and annunciators. If a failure is detected, the instrument will not enter the measurement state.

### 3.3.3 Power-up Defaults

The power-on default will be the last configuration you saved.

### 3.3.4 Warm-up Time

AT680 is ready to be used as soon as the power-up sequence has completed. However, to achieve the accuracy rating, warm up the instrument for 30 minutes.

## 3.4 Measurement configuration

### 3.4.1 Connection to Device under Test (DUT)

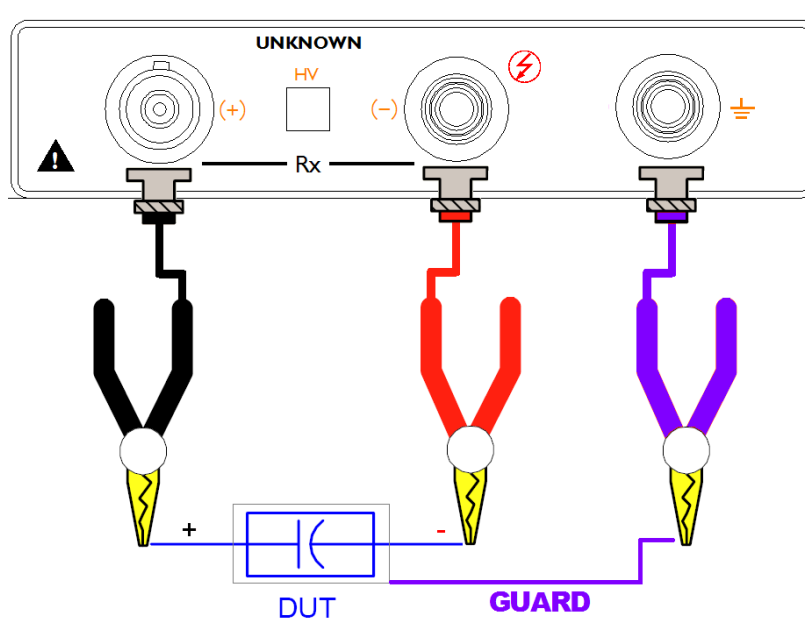

Figure 3-6 Connection to DUT



1. The negative terminal output high voltage, the piece should be linked in the discharge state to avoid being electric shock.
2. Warning: Such as capacitor which has nonpolarity should be linked in the correct way , or it is dangerous for the human being.
3. Recommend: Device discharges build in the machine.
4. Ensure that the operating environment meets the requirements.

### 3.4.2 Voltage

Voltage Input box accepts entry of a test voltage between 1.0 and 650 VDC.  
 <100V in 0.1V intervals, ≥100V in 1V intervals.

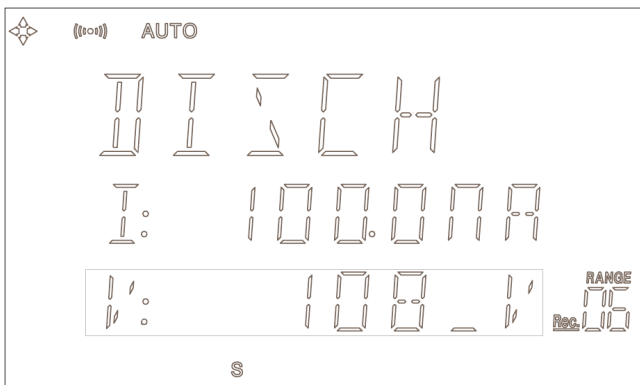

#### Discharge State

1. Press **[Voltage]** key, a cursor flashed at 3<sup>rd</sup> line on the VFD.
  2. Press Numeric Key Enter value.
  3. Press **[Enter]** to finish input, the Value will save in Flashrom and back to Discharge State.
- Press **[Esc]** key to cancel input and back to Discharge State.

### 3.4.3 Range

In the auto range state, AT680 choose the right range as illustrated in table 3-1.

Table 3-1 Range changes process



NO.	lifting range	Lower range
1	↓ 2mA	↑ 1.8mA
2	↓ 200μA	↑ 180μA
3	↓ 20μA	↑ 18μA
4	↓ 2μA	↑ 1.8μA
5	↓ 200nA	↑ 180nA
6	↓ 20nA	↑ 18nA
7	↓	↑

If you don't choose the fit range, you wouldn't get the result in the standard accuracy.

If you don't know the measured range ,you use the auto range to measure.Press the

**Range** key to light the **AUTO** mark.

If you set-up the refer value , you can measure in the manual range, Press the **Range** key to die out the **AUTO** mark, the AT680 would choose the range by the refer value.

Press **Range**   key to set-up Manual range.

TIP : 

- Manual range is help increasing the test rate.
- In the auto range state, some device (such as CBB) won't be chosen the correct range; you can use the manual range.
- When you measure the leak current, the manual range is a better choice.
- When you measure in the Fast/Med, the manual range is a better choice.

### 3.4.4 Charge Timer

Accepts entry of a charge time between 0 and 999.9 seconds in 0.1 second.



1. Under discharge state, press **Timer** key into timer window. Rotate knob to choose "CHARG" item and enter setup window.
2. Press **Numeric** Keys to Enter time value.
3. **Enter** key can be pressed to finish the input.
4. Press **Esc** to save time value or Press **Enter** key to exit setup window.

NOTE : 

If charge time value set to 0s, the charge timer will be disabled.

### 3.4.5 Sample Timer

Accept entry of a sample time between 0 and 999.9 seconds in 0.1 second. In the measurement state, AT680 will sample a data every sample time.

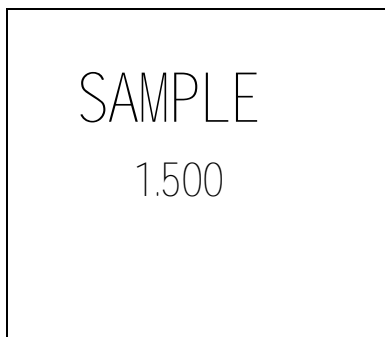

1. Under discharge state, press **Timer** key into timer window. Rotate knob to choose "SAMPLE" item and enter setup window.
2. Press **Numeric** Keys to enter time value.
3. **Enter** key can be pressed to finish the input.
4. Press **Esc** to save time value or Press **Enter** key to exit setup window.

TIP : 

If sample time value set to 0s, the sample timer will be disabled, 1s step, the maximum value is 999.9s.

You can setup the sample timer in the discharge state.

**The sample timer is enabled in the external trigger state.**

If sample time value set to 0s, charge timer is disabled.

Flow :

In the external trigger state, the machine get the trigger signal, output the high voltage and timer is on, the machine sample each time and the output is off that the timer is to 0. In the same time, the handler interface output the sorting result (EOC, GD/NG) until get another trigger signal.

### 3.4.6 Clear Zero Correction (Zeroing)

Before making measurements, AT680 should be zeroed to correct for test lead or fixture errors.

1. Press **Clear** key to enter clear window. Before zeroing, remove all components from test fixture.



NOTE:

The (+) test lead must be opened and suspended. NO touching any objects (such as table).

2. Press **Enter** to clear zero.

During the zeroing process corrections are calculated and stored in AT680 flashrom and applied to ongoing measurements.

3. Press **Esc** to terminate clearing process and exit zeroing window.

### 3.4.7 Adjust VFD Brightness

Press **Shift** **Brightness** key to adjust VFD Brightness.

The first line of VFD displays “VFD-LT” and the 2<sup>nd</sup> line shows current brightness level. Press **←**, **→** or turn the **Knob** to change a new level.

Press **Enter** to save and exit to discharge state. Press **Esc** to exit to discharge state but not save.

Brightness includes 8 levels:  
0(dark) ~ 7(bright)

## 3.5 Measurement Procedure

### 3.5.1 Charge – Test - Discharge

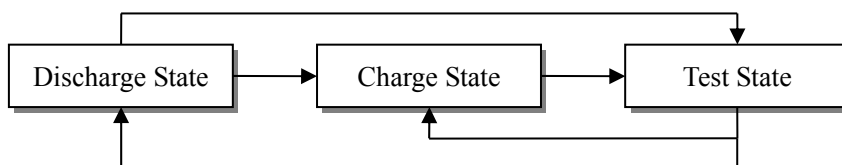
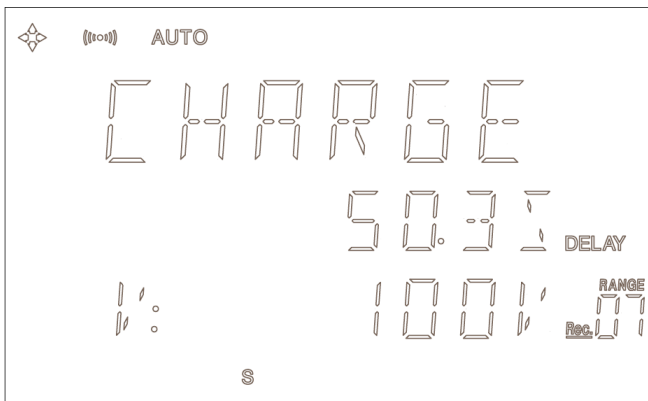



Figure 3-9 Three States

**Charge State:**

1. Press **Charge** key to enter charge state.
2. The (-) terminal outputs negative voltage and charge timer starts.
3. After timer decreasing to zero, the state will be switched to “Test State”.
4. Press **Charge** key again to enter “Test State” directly. The available time will be ignored.

TIP : 

If the charge time set to 0, the charge timer would be closed.

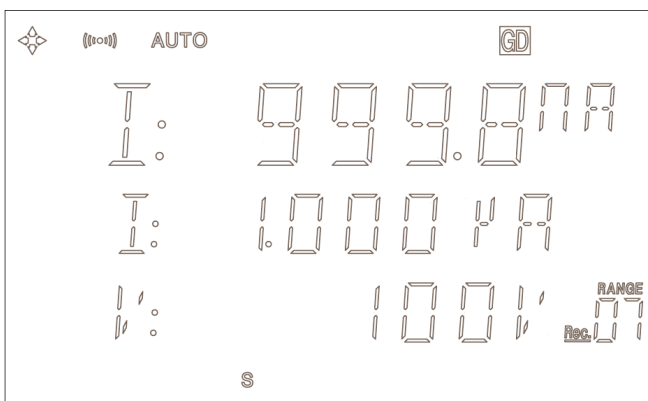
**Test State:**

If the charge timer closed, press **Charge** key will enter TEST STATE.

At TEST STATE, press **Charge** key to enter CHARGE STATE again.

TIP : 

If you close the power, the value of the parameter you change would be lost, because of altering the parameter in the test state; the value would be stored in the discharge .state.

### 3.5.2 Changing the Parameter

You can change test parameter whether at DISCHARGE STATE or TEST STATE.

Press **Param** key to switch IR to current testing.

Press the **Param** key to cut over insulation resistance to leakage current.

In the discharge state, the 2<sup>nd</sup> line displays the limit value which also is the present parameter.

If you want to measure the Insulation resistance, make sure the first letter of the 2nd line is “R:”

If you want to measure the leakage current, make sure the first letter of the 2nd line is “I”.

### 3.5.3 Rate

The RATE operation sets the integration time of the A/D converter, the period of time the input signal is measured (also known as aperture). The integration time affects the usable digits, the amount of reading noise.

The RATE items are explained as follows, you can press **Rate** key to choose.

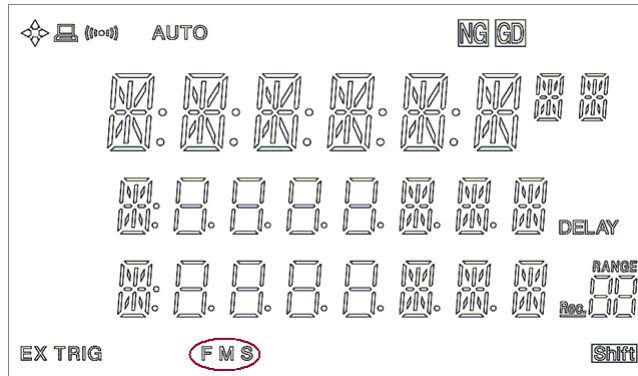
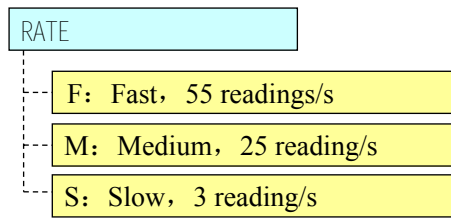

### 3.5.4 Display IR and Leakage at one time.

AT680 can display IR at 1<sup>st</sup> line of the VFD and Leakage current at 2<sup>nd</sup> line.  
Under TEST STATE, Press **View** key to choose follow items at 2<sup>nd</sup> line:

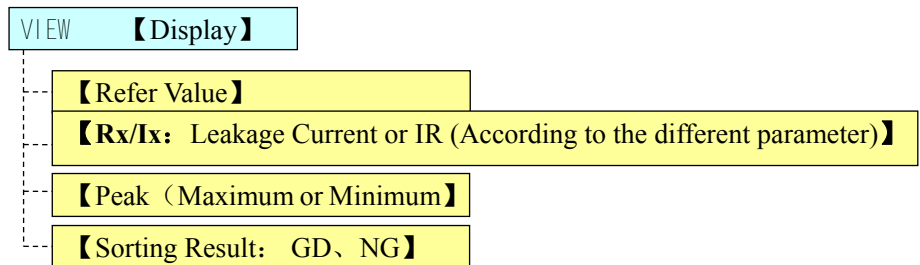

TIP : 

Sorting Result is compared by the the parameter at 1<sup>st</sup> line.

### 3.5.5 Display Peak

Press **View** key to display peak at VFD 2<sup>nd</sup> line.  
In the Test State, Press the **View** key to choose follow items:

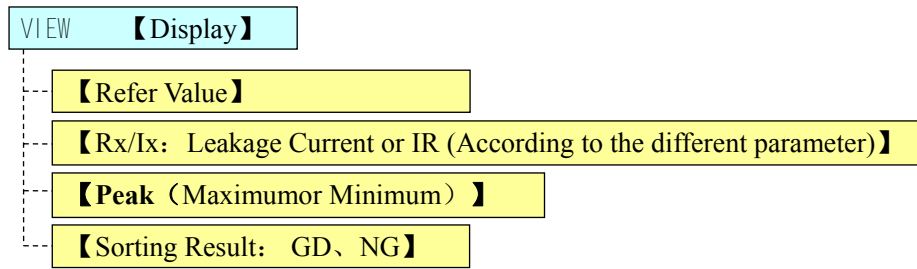

TIP : 

IR's peak is Minimum, the MIN annunciator displayed.

Leakage Current's peak is Maximum, the MAX annunciator displayed.

### 3.5.6 Sorting Result displays at 2nd line

Press **View** key to display peak at VFD 2<sup>nd</sup> line.

In the Test State, Press the **View** key to choose follow items:

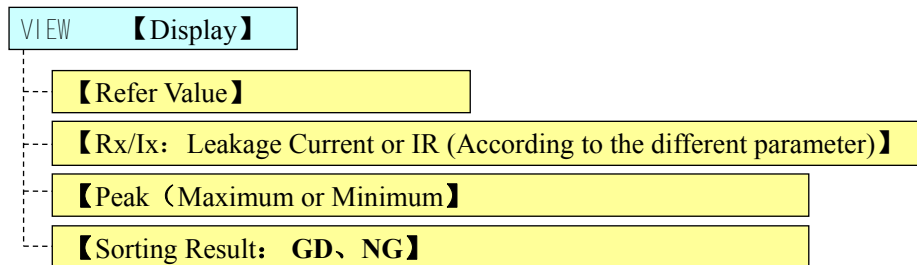

### 3.5.7 Turning ON/OFF the Beep Feature.

Press the **Beep** key to turn on/off the beep feature.

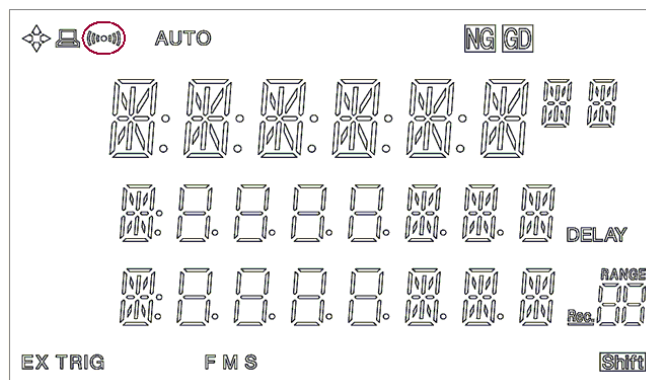

### 3.5.8 Set Trigger ( Trigger<sup>Shift</sup> )



Trigger: Internal, Manual (Remote) and External Trigger  
 Press **Shift** + **Enter** to enter the trigger state.  
 The Trigger mode toggled each time that you press the key.  
 Internal Trigger : “EX TRIG” Mark die out .  
 Manual (Remote) Trigger: “TRIG”Mark is lighten  
 External Trigger: “EX TRIG”Mark is lighten,

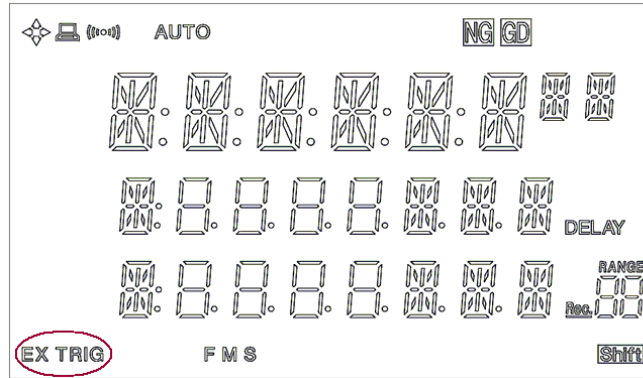

### 3.5.9 Remote

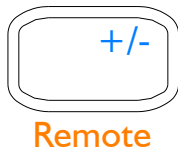

Press **Remote** to turn on/off the serial communication interface  
 mark lighted, remote control is enabled.

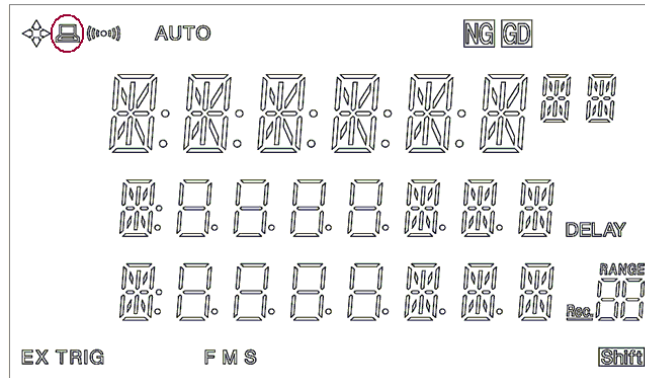

**Setting:** Press **Shift** +/- enter **Remote** state.

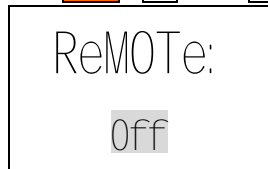

Press **Left/Right** key or Turn Knob to choose following items:



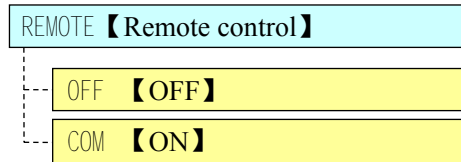

**Exit:** Press **Esc** key to exit to DISCHARGE STATE and the setting saved.

**Execute:** Press **Enter** key to Baud STATE and the setting saved.

Choose the Baud and Press **Enter** to exit to DISCHARGE STATE and the setting saved.

The machine could be connected to the computer with the serial interface to control when the serial communication interface is on.

# 4 Comparator



This chapter provides information about comparator:

- Inputs limit reference value.
- Setup beep feature.

## 4.1 Input Limit reference value

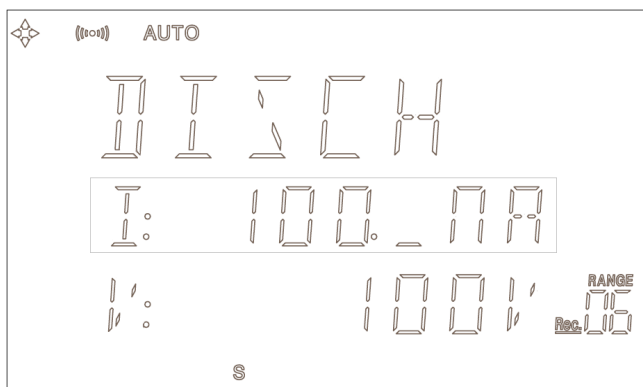

1. Under DISCHARGE STATE, Press **Refer** key, a cursor flashed.
2. Press Digits to input value.
3. Press **Shift** + n/μ/m/k/M/G to key in unit. The value saved.  
Press **Esc** to cancel and exit to DISCHARGE STATE.

NOTE :

The Resistance's limit reference value is UPPER limit.  $R_x \geq \text{Refer}$ , PASS (GD).  
The Leakage Current's limit reference value is LOWER limit.  $I_x \leq \text{Refer}$ , PASS.

## 4.2 Set Beep Feature:

### 4.2.1 Turning on/off the beep :

Press **Beep** to turn on/off the beep.

The beep annunciator shows you the beep on/off state.

### 4.2.2 Set Beep :

1. Press **Shift** **Beeper** key to enter beep set window.
2. Press **←** **→** key or Turn Knob to choose following items:
  - GD Beep while pass.
  - NG Beep while fail.
3. Press **Enter** key to exit to DISCHARGE STATE and the setting saved.

- 
4. Press **Esc** key to exit to DISCHARGE STATE and the setting without being saved.

### 4.2.3 How the comparator work

Under TEST STATE, the comparator determines whether the measurement result (displayed value) is within the upper or lower limits set by the **Refer** Comparator Limit key. The comparator function is always ON. The comparison results can be displayed on the VFD display, can be output to the handler interface, or can be revealed by the beeper.

**Comparator work flow:**

Insulation Resistance:

$R_x \geq R_{refer}$ (Upper value)	PASS	Display GD
$R_x < R_{refer}$ (Upper value)	FAIL	Display NG

Leakage Current:

$I_x \leq I_{refer}$ (Lower value)	PASS	Display GD
$I_x > I_{refer}$ (Low		

# 5 Handler Interface



This chapter describes how to use the handler interface.

- Pin Assignment
- Circuit Diagram
- Timing Chart

By using the handler interface, you can output the measurement completion signal (EOC), the screening result of the comparator function (GD/NG), and so on to external devices from the AT680. You can also input the external trigger signal and the comparator select signal to the AT680. With this interface and the comparator function, you can build an automatic screening system composed of the AT680 and the handler.

## 5.1 Pin Assignment

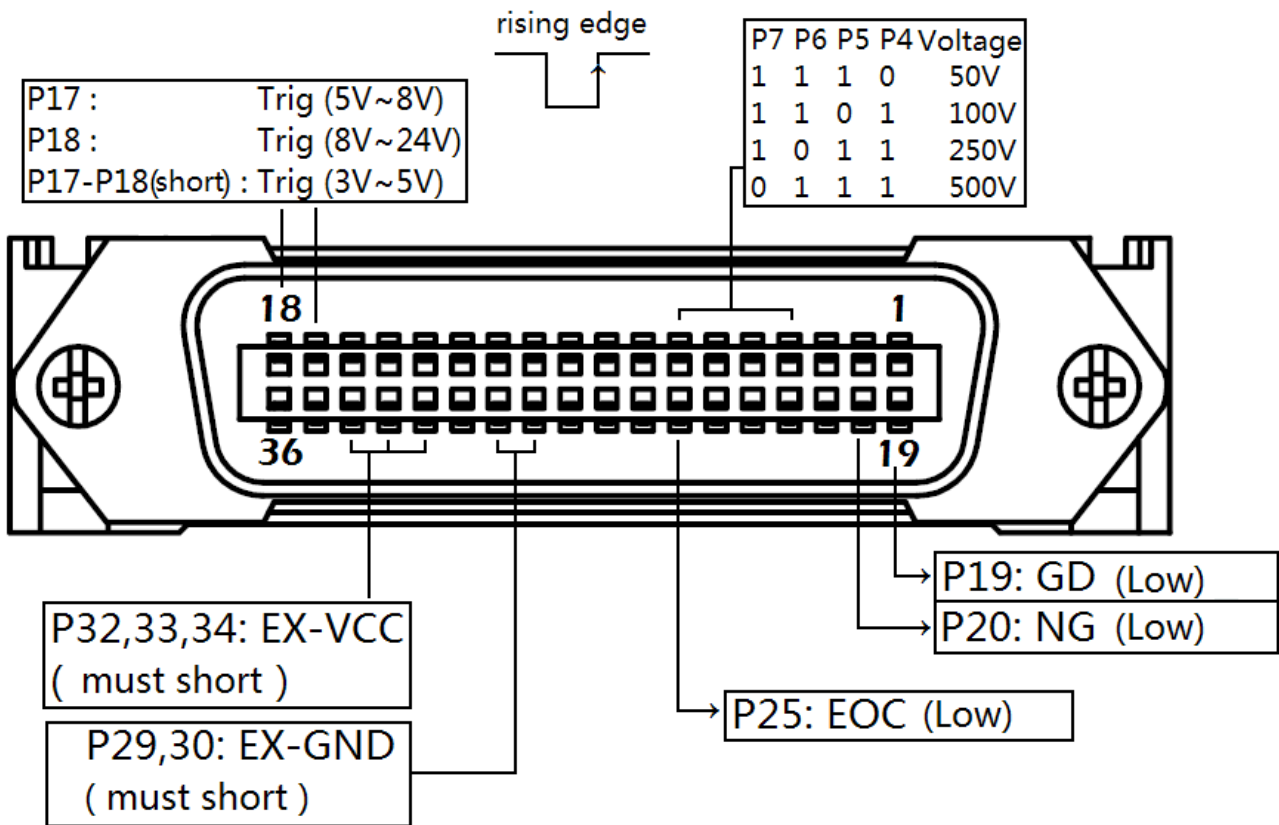

Figure 5-1 Pin Assignment of Handler Interface Connector

Table 5-1 Description of Handler Interface Input Signals

9	COMP.0	Comparator Record Selector. (1 thru 30)
10	COMP.1	
11	COMP.2	See Table 5-1.

12	COMP.3	
13	COMP.4	
14	DISCH	Discharge. (Low)
15	CHARG	Charge and Test. (Low)
17	TRIG8V	External Trigger Signal  (Rising edge) 17-18 SHORT = TRIG5V
18	TRIG24V	

Table 5-2 Comparator Record Selection Truth Table

COMP 4-0	Record	COMP 4-0	Record	COMP 4-0	Record	COMP 4-0	Record
1111	No change	1011	8	0111	16	0011	24
1110	1	1010	9	0110	17	0010	25
11101	2	10101	10	01101	18	00101	26
11100	3	10100	11	01100	19	00100	27
11011	4	10011	12	01011	20	00011	28
11010	5	10010	13	01010	21	00010	29
11001	6	10001	14	01001	22	00001	30
11000	7	10000	15	01000	23	00000	No change

Table 5-3 Output Signals

4	EX0	See Tale 5-4.
5	EX1	
6	EX2	
7	EX3	
7	EOC	Measurement completion signal. (Low)
19	GD	Pass signal. (Low)
20	NG	Fail signal. (Low)

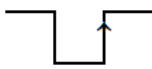
Table 5-4 Typical Voltage Control Signal

EX3	EX2	EX1	EX0	Voltage
1	1	1	0	50V
1	1	0	1	100V
1	0	1	1	250V
0	1	1	1	500V

Table 5-5 Power Signal

27	IN-GND	<i>Internal GND: Not Recommend to use</i>
28	IN-GND	
29	EX-GND	External GND
30	EX-GND	
32	EX-VCC2	External VCC1: Pull-up Resistance(5kΩ) Power Supply
33	EX-VCC1	External VCC2: Main Power Supply

34	EX-VCC1	
35	IN-VCC	<i>Internal 3.3V: Not Recommend to use</i>
36	IN-VCC	

## 5.2 Electrical Characteristics

### Input Signal:

Each input signal is connected to the LED (cathode side) of the photo-coupler. The LED (anode side) is connected to the pull-up power supply voltage.

### Output Signal:

Each output signal is outputted via an open collector by using a photo-coupler. The voltage of each output is obtained by connecting pull-up resistors, inside or outside of the AT680.

#### NOTE:

If the external power supply greater than 8VDC, use external pull-up resistance please.

The Pin 32 leaves float.

The output signal current can not drive relay.

### Power supply

The power supply for the judgment output signal pull-up and that for the operation output signal pull-up and input signal drive can be set separately. You can select +3.3V of the internal power supply or from +3.3V to +24V external power supply.

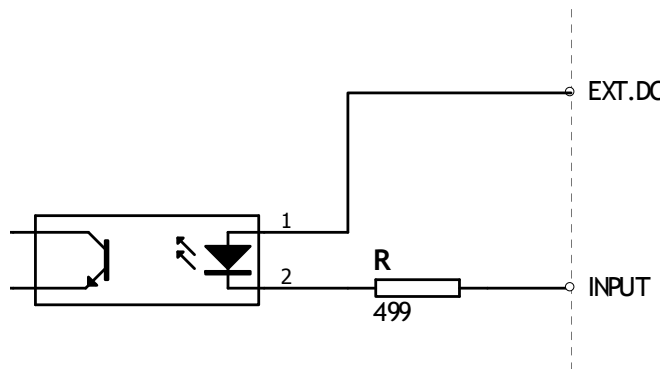

Figure 5-2 Typical Circuit Diagram of Handler Interface Input signals.

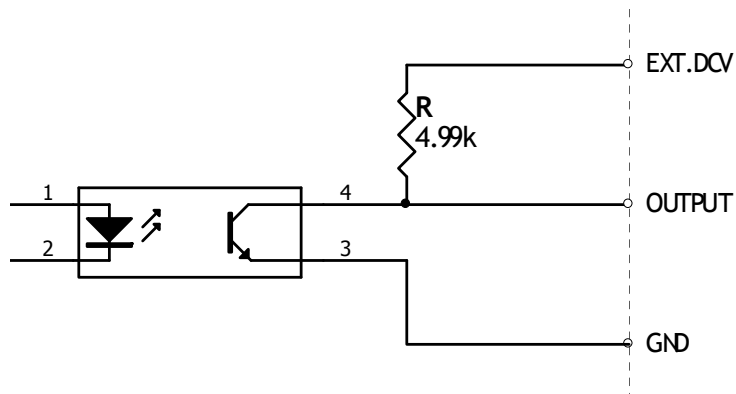

Figure 5-3 Typical Circuit Diagram of Handler Interface Output signals.

### 5.3 Timing Chart

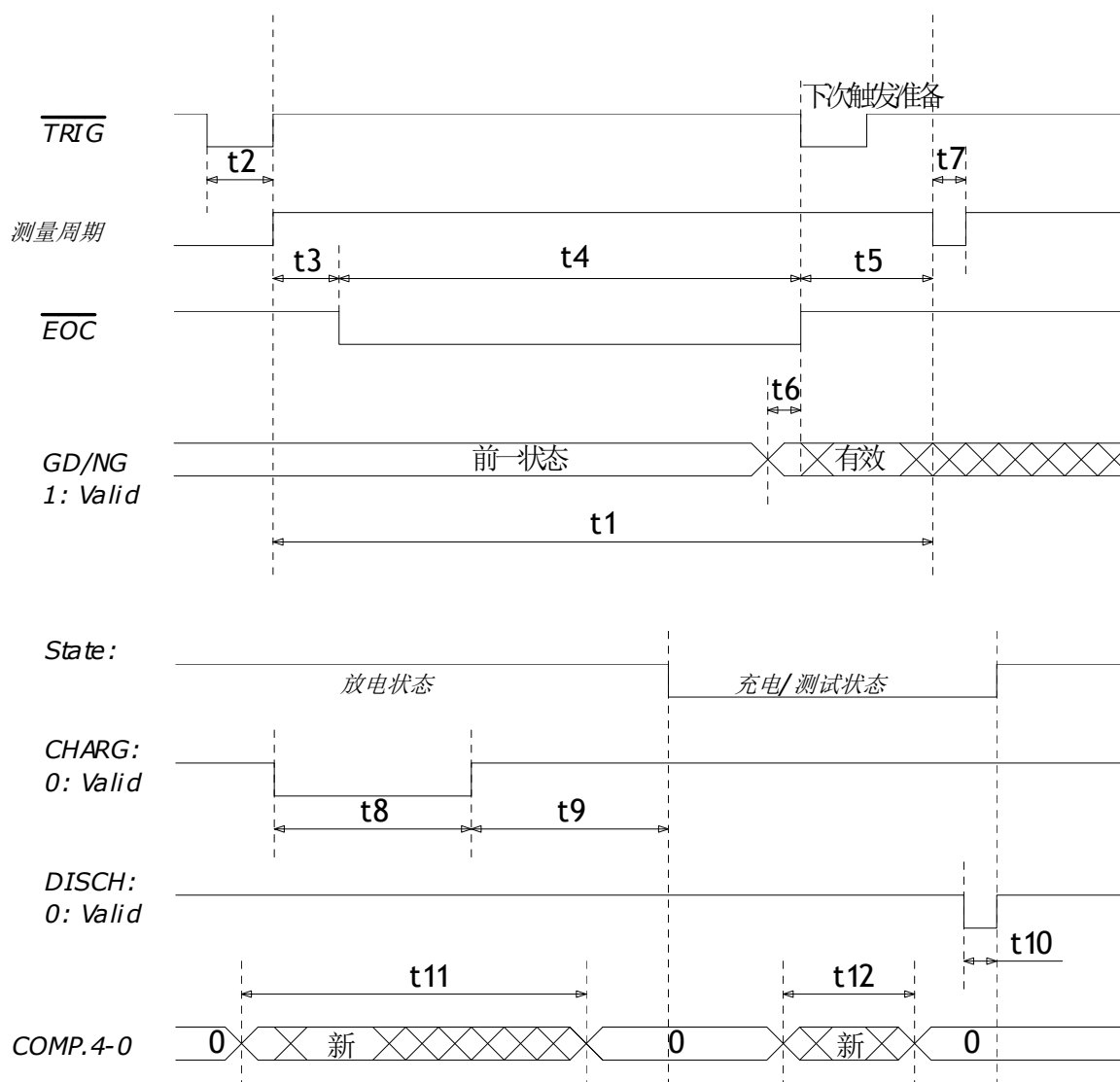

Figure 5-4 Timing Chart

Description		Time (App.)		
		Min.	Typical	Max.
t1	One Measurement Circle	Fast	-	17ms
		Med	-	67ms
		Slow	-	260ms
t2	Trigger pulse width	1ms	-	-
t3	Trig Delay Time	-	1ms	-
t4	AD Time ( EOC[BUSY] )	Fast	-	12.2ms
		Med	-	62.6ms
		Slow	-	256ms
t5	Print Result Time	4ms	4.4ms	4.8ms
t6	Handler Out to EOC Time	-	10μs	-
t7	Next Start Time	-	10μs	-
t8	CHARG Signal Hold Time	50ms	-	110ms

t9	CHARG to Measure Delay Time	-	100ms	-
t10	DISCH Signal Hold Time	10ms	-	-
t11	Under DISCHARGE STATE, The Record Signals Hold Time	100ms	-	-
t12	Under TEST STATE, The Record Signals Hold Time.			=t1



# 6 Remote Control



This chapter provides the following information to remotely control the AT68x via the RS-232C interface.

- About RS-232C
- RS-232C operation.
- SCPI

AT680 can use the RS-232 interface to communicate with the computer to complete all the instrument functions.

## 6.1 About RS-232C

You can connect a controller (i.e. PC and PLC) to the RS-232 interface using Applent RS-232 DB-9 cable. The serial port uses the transmit (TXD), receive (RXD) and signal ground (GND) lines of the RS-232 standard. It does not use the hardware handshaking lines CTS and RTS.



NOTE:

JUST ONLY Use an Applent (not null modem) DB-9 cable.

Cable length should not exceed 2m.

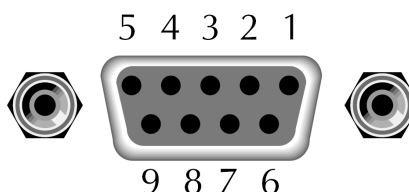

Figure 6-1 The RS-232 connector in the real panel

Table 6-1 RS-232 connector pinout

NAME	DB-25	DB-9	NOTE
DCD	8	1	Not Connection
RXD	3	2	Transmit data
TXD	2	3	Receive date
DTR	20	4	Not Connection
GND	7	5	Ground
DSR	6	6	Not Connection
RTS	4	7	Not Connection
CTS	5	8	Not Connection

- Make sure the controller you connect to AT680 also uses these settings.

The RS-232 interface transfers data using:

8 data bits,

1 stop bit,

And no parity.

## 6.2 Enable RS-232C Interface and select baud rate

To enable RS-232 interface, do the following:

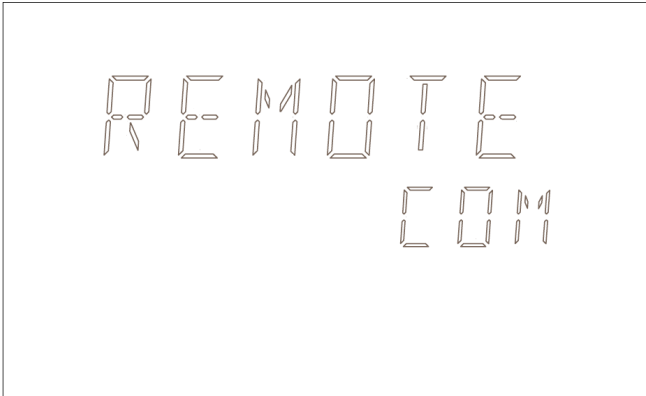

1. Under DISCH state, press **SHIFT** **Remote** key into REMOTE window.
2. Rotate knob to choose "COM" item.
3. **Enter** key enable RS-232.
4. Rotate knob to choose 4800 / 9600/ 19200/ 38400/ 57600 items.
5. Confirm your selection by pressing ENTER.



## 6.3 SCPI Language

Standard Commands for Programmable Instruments (SCPI) is fully supported by the RS-232 interfaces.

---



NOTE:  
AT680 ONLY supports the SCPI Language.

---

# 7 Command Reference



This chapter contains reference information on programming AT680 with the SCPI commands.

This chapter provides descriptions of all the AT680's available RS-232 commands which correspond to Standard Commands for Programmable Instruments (SCPI) command sets, listed in functional subsystem order.

## 7.1 Terminator

NL: The EOI line is asserted by New Line or ASCII Line Feed character (decimal 10 , Hex 0x0A, or ASCII '\n')

## 7.2 Notation Conventions and Definitions

The following conventions and definitions are used in this chapter to describe RS-232 operation.

< > Angular brackets enclose words or characters that are used to symbolize a program code parameter or an RS-232 command.

[ ] A square bracket indicates that the enclosed items are optional.

\n Command Terminator

## 7.3 Command Structure

The AT680 commands are divided into two types: Common commands and SCPI commands.

The common commands are defined in IEEE std. 488.2-1987, and these commands are common for all devices. The SCPI commands are used to control all of the AT68x's functions.

The SCPI commands are tree structured three levels deep. The highest level commands are called the subsystem commands in this manual. So the lower level commands are legal only when the subsystem commands have been selected.

A colon (:) is used to separate the higher level commands and the lower level commands.

Semicolon (;) A semicolon does not change the current path but separates two commands in the same message.

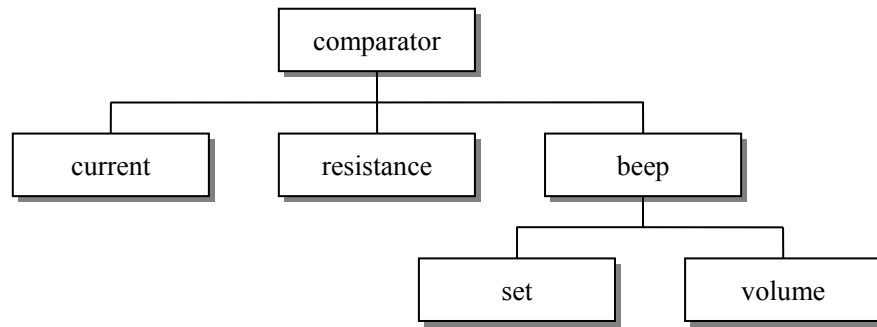

Figure 7-1. Command Tree Example

Example:

```

comp:beep:set ng\n
comp      Subsystem Command
  beep    Level 2
    set    Level 3
      ng    Parameter
    
```

- The basic rules of the command tree are as follows.
  - Letter case (upper and lower) is ignored.  
For example,  
**COMPARATOR:RESISTANCE = comparator: resistance**
  - Spaces ( \_ used to indicate a space) must not be placed before and/or after the colon (:).  
For example,  
 **comparator\_:\_resistance** →  **comparator: resistance**
  - The command can be completely spelled out or in abbreviated.(The rules for command abbreviation are described later in this section)  
For example,  
**comparator: resistance = comp:res**
  - The command header should be followed by a question mark (?) to generate a query for that command.  
For example,  
**comp:res?**
  - The semicolon (;) can be used as a separator to execute multiple commands on a single line. The multiple command rules are as follows.  
Commands at the same level and in the same subsystem command group can be separated by a semicolon (;) on a multiple command line.  
For example,  
**comp: beep: set ng; vol low**  
To restart commands from the highest level, a semicolon (;) must be used as the separator, and then a leading colon (:), which shows that the restarted command is a command at the top of the command tree, must follow.  
For example,  
**comp:beep:set ng;[:]comp:r 100e6**
  - The common commands can restart only after a semicolon on a multiple command line.  
For example,

**func:rang 8;\*IDN?:auto on**

## • Command abbreviations:

Every command and character parameter has at least two forms, a short form and a long form. In some cases they will be the same. The short form is obtained using the following rules.

A) If the long form has four characters or less, the long form and short form are the same.

B) If the long form has more than 4 characters:

(a) If the 4th character is a vowel, the short form is the first 3 characters of the long form.

For example:

comparator	abbr. to	comp
current	abbr. to	curr
range	abbr. to	rang

(b) If the 4th character is not a vowel, the short form is the first 4 characters.

For example:

resistance	abbr. to	res
volume	abbr. to	vol

• If the long form mnemonic is defined as a phrase rather than a single word, then the long form mnemonic is the first character of the first word(s) followed by the entire last word. The above rules, when the long form mnemonic is a single word, are then applied to the resulting long form mnemonic to obtain the short form.

For example:

PercentTolerance	abbr. to	ptol
------------------	----------	------



---

AT68x accepts the three forms of the same SCPI commands: all upper case, all lower case, and mixed upper and lower case.

---

## 7.4 Header and Parameters

The commands consist of a command header and parameters. (See the following.)

*For example*

```
comp:res 100.0e6
```

Header	Parameter
--------	-----------

- Headers can be of the long form or the short form. The long form allows easier understanding of the program code and the short form allows more efficient use of the computer.
- Parameters may be of two types as follows.
  - (A) Character Data and String Data Character data consists of ASCII characters. The abbreviation rules are the same as the rules for command headers.
  - (B) Numeric Data
    - (a) interger: For example, 1,+123,-123
    - (b) fix float: For example, 1.23,+1.23,-1.23

(c) floating point: For example, 1.23e3, 5.67e-3, 123k, 1.23M, 2.34G,

The available range for numeric data is 9.9E37. When numeric data is used as a parameter, the suffix multiplier mnemonics and suffix units (The suffix multiplier must be used with the suffix unit.) can be used for some commands as follows.

Table 7-1 **Multiplier Mnemonics**

Definition	Mnemonic
1E18 (EXA)	EX
1E15 (PETA)	PE
1E12 (TERA)	T
1E9 (GIGA)	G
1E6 (MEGA)	MA
1E3 (KILO)	K
1E-3 (MILLI)	M
1E-6 (MICRO)	U
1E-9 (NANO)	N
1E-12 (PICO)	P
1E-15 (PEMTO)	F
1E-18 (ATTO)	A

## 7.5 Command Reference

All commands in this reference are fully explained and listed in the following functional command order.

- FUNCTION
- VOLTage
- CORRection
- COMParator
- STATe
- TIMEr
- APERture
- SYSTem
- TRIGger
- FETCh?
- ERRor

Common Command:

- \*IDN?
- \*RST

The explanation of each subsystem command is patterned as follows.

1. Subsystem command name
2. Command Tree (Subsystem command only)
3. Compound Command Name
4. Command Description
5. Command Syntax
6. Example Using the Above Command Syntax

- 7. Query Syntax
- 8. Query Response
- 9. Example Using the Above Query Syntax
- 10. Constraints

## 7.6 Function Subsystem

The **FUNCTION** subsystem command group sets the measurement parameter and measurement range.

Figure 7-2  
FUNCTION  
Command Tree

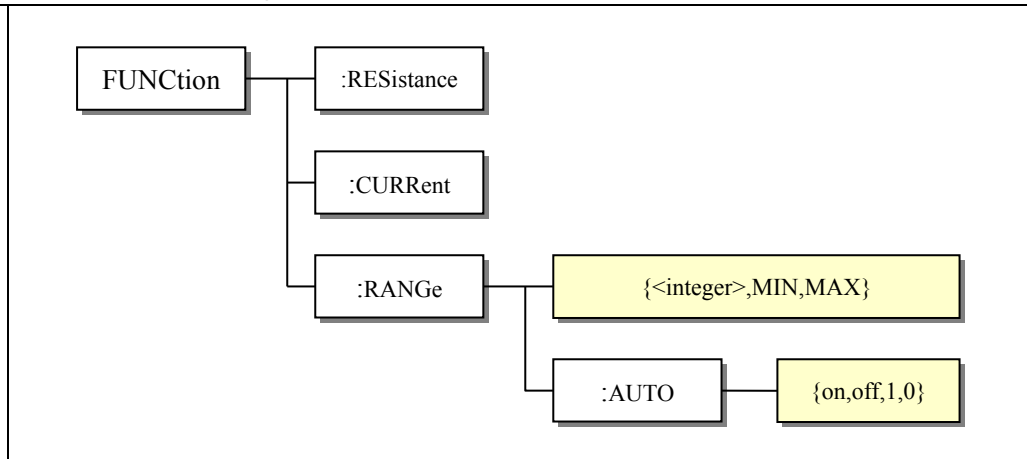

### :RESistance

The **:RESistance** command sets the measurement parameter to resistance (R).

Command Syntax	<b>FUNCTION:RESistance\n</b>
Parameters	none
Query	none
Constraints	none

### :CURRent

The **:CURRent** command sets the measurement parameter to current (I).

Command Syntax	<b>FUNCTION:CURRent\n</b>
Parameters	none
Query	none
Constraints	none

### :RANGe

The **:RANGe** command sets the measurement range. If the current range was AUTO, then converted to manual.

Command Syntax	<b>FUNCTION:RANGe {&lt;integer&gt;,MIN,MAX}</b>
----------------	---

<b>Parameters</b>	{<integer>, MIN, MAX} where , <interger> Range no from 1 to 7. MIN =1 MAX =7
<i>For example :</i>	<b>Tx&gt;</b> func:rang 5 //set range to 5 <b>Tx&gt;</b> func:rang min //set range to 1 <b>Tx&gt;</b> func:rang max //set range to 7
<b>Query Syntax</b>	<b>FUNCTION:RANGe?</b>
<b>Query Response</b>	<integer> Range no from 1 to 7.
<i>For example :</i>	<b>Tx&gt;</b> func:rang? <b>Rx&gt;</b> 6
<b>Constraints</b>	none

### :RANGe:AUTO

The :RANGe:AUTO command sets the auto range to ON or OFF.

<b>Command Syntax</b>	<b>FUNCTION:RANGe:AUTO {ON,OFF,1,0}</b>
<b>Parameters</b>	{ON,OFF,1,0} where, 1 :=ON , ASCII(decimal 49) , 0 :=OFF , ASCII(decimal 48)
<i>For example :</i>	<b>Tx&gt;</b> func:rang:auto off //The auto range will set to manual.
<b>Query Syntax</b>	<b>FUNCTION:RANGe:AUTO?</b>
<b>Query Response</b>	{on,off}
<i>For example :</i>	<b>Tx&gt;</b> func:rang:auto? <b>Rx&gt;</b> off
<b>Constraints</b>	none

## 7.7 VOLTage Subsystem

The VOLTage subsystem sets test voltage.

Figure7-3  
VOLTage  
Command Tree

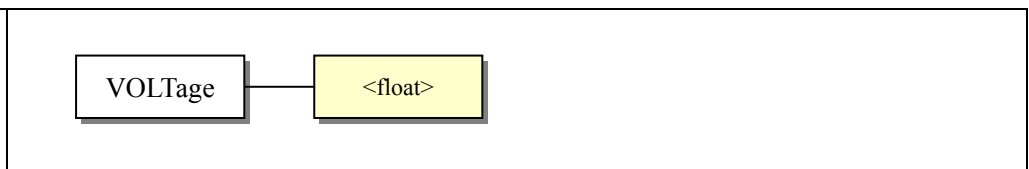

<b>Command Syntax</b>	<b>VOLTage &lt;float&gt;</b>
<b>Parameters</b>	<float> 1.0~650
<i>For example :</i>	<b>Tx&gt;</b> VOLT 10.2 <b>Tx&gt;</b> VOLT 500
<b>Query Syntax</b>	<b>VOLTage?</b>
<b>Query Response</b>	<float> 1.0~650.0



For example : **Tx> VOLT?**  
**Rx> 10.0**

**Constraints** Available under DISCH state

## 7.8 CORRection Subsystem

The **CORRection** subsystem command group sets the OPEN correction function.

Figure 7-4  
 CORRection  
 Command Tree



**Command Syntax** **CORRection**

**Parameters** none

For example : **Tx> CORR**  
**Rx> Clear 0 process, please wait.**  
**Rx> ok.**

**Query Syntax** none

**Constraints** none



**NOTE:**  
 When clearing, the instrument will ignore any commands.

## 7.9 COMParator Subsystem

The **COMParator** subsystem command group sets the comparator function, including its RECORD NO, LIMIT REFERENCE VALUES and BEEP.

Figure 7-5  
 COMParator  
 Command Tree

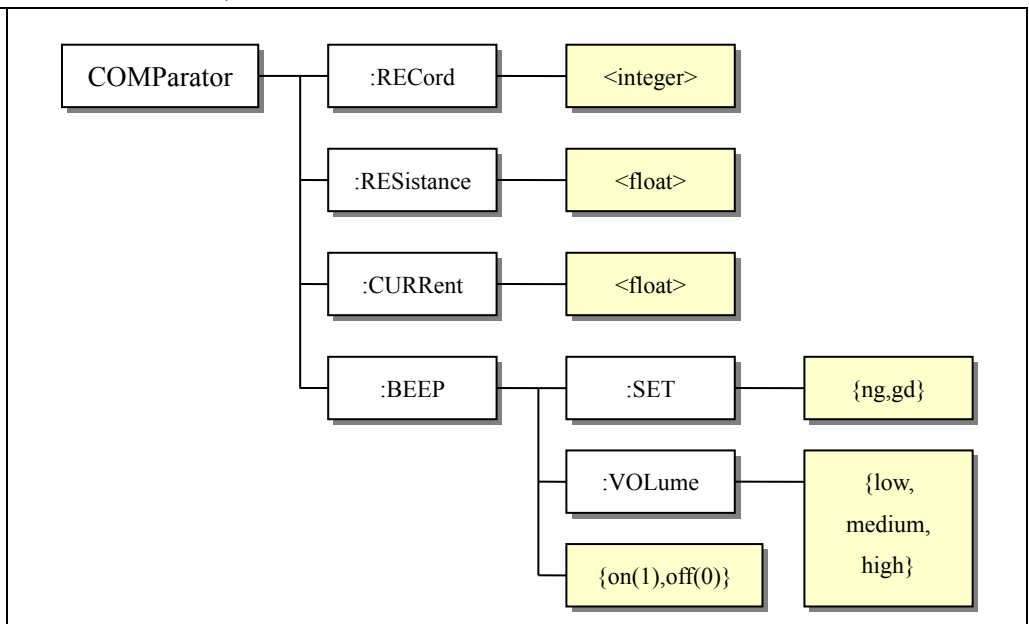

### :RECORD

The **:RECORD** command sets Record number.

<b>Command Syntax</b>	<b>COMPparator:RECORD &lt;integer&gt;</b>
<b>Parameters</b>	<integer> 1-30
<i>For example :</i>	<b>Tx&gt;</b> COMP:REC 2 //sets current record to 2
<b>Query Syntax</b>	<b>COMPparator:RECORD?</b>
<b>Query Response</b>	<integer> 1-30
<i>For example :</i>	<b>Tx&gt;</b> COMP:REC? <b>Rx&gt;</b> 2
<b>Constraints</b>	Available under DISCH state

### :RESISTANCE

The **:RESISTANCE** command sets resistance limit value.

<b>Command Syntax</b>	<b>COMPparator:RESISTANCE &lt;float&gt;</b>
<b>Parameters</b>	<float> fix float or floating point , 0-99999G
<i>For example :</i>	<b>Tx&gt;</b> COMP:RES 100G //100G Ω
<b>Query Syntax</b>	<b>COMPparator:RESISTANCE?</b>
<b>Query Response</b>	<float> floating point
<i>For example :</i>	<b>Tx&gt;</b> COMP:RES? <b>Rx&gt;</b> 1.234560e+08
<b>Constraints</b>	Available under DISCH state

### :CURRENT

The **:CURRENT** command sets current limit value.

<b>Command Syntax</b>	<b>COMPparator:CURRENT &lt;float&gt;</b>
<b>Parameters</b>	<float> fix float or floating point, 0-99999m
<i>For example :</i>	<b>Tx&gt;</b> COMP:CURR 1m //1mA
<b>Query Syntax</b>	<b>COMPparator:CURRENT?</b>
<b>Query Response</b>	<float> floating point
<i>For example :</i>	<b>Tx&gt;</b> COMP:CURR? <b>Rx&gt;</b> 1.000000e-06
<b>Constraints</b>	Available under DISCH state

### :BEEP

The **:BEEP** command set beep to ON or OFF.

<b>Command Syntax</b>	<b>COMPparator:BEEP {on (1) ,off (0) }</b>
<b>Parameters</b>	{on (1) ,off (0) }

<i>For example :</i>	<b>Tx&gt;</b> COMP:BEEP on
<b>Query Syntax</b>	<b>COMParator:BEEP?</b>
<b>Query Response</b>	{on, off}
<i>For example :</i>	<b>Tx&gt;</b> COMP:BEEP? <b>Rx&gt;</b> on
<b>Constraints</b>	none

**:BEEP:SET**

The **:BEEP:SET** command sets ng beep or gd beep.

<b>Command Syntax</b>	<b>COMParator:BEEP:SET {ng, gd}</b>
<b>Parameters</b>	{ng, gd}
<i>For example :</i>	<b>Tx&gt;</b> COMP:BEEP:SET ng
<b>Query Syntax</b>	<b>COMParator:BEEP:SET?</b>
<b>Query Response</b>	{ng, gd}
<i>For example :</i>	<b>Tx&gt;</b> COMP:BEEP:SET? <b>Rx&gt;</b> ng
<b>Constraints</b>	none

## 7.10 STATE Subsystem

The STATE subsystem sets instrument state to CHARG or DISCH.

Figure 7-6  
STATE  
Command Tree

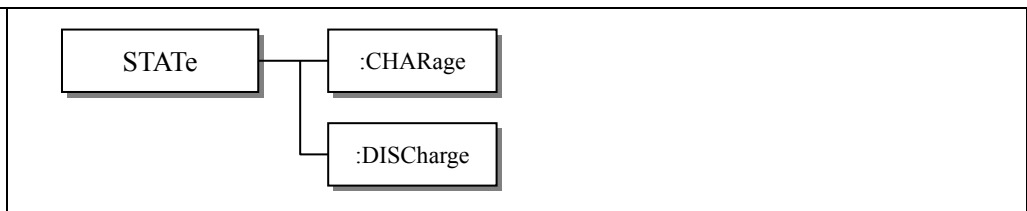

<b>Query Syntax</b>	<b>STATe?</b>
<b>Query Response</b>	{charge, discharge, test} where , charge: CHARGE state discharge: DISCH state test: TEST state
<i>For example :</i>	<b>Tx&gt;</b> STATe? <b>Rx&gt;</b> discharge
<b>Constraints</b>	none



**NOTE:**  
All commands after state subsystem will be ignored.

**:CHARge**

<b>Command Syntax</b>	<b>STATe:CHARge</b>
<b>Parameters</b>	none
<i>For example :</i>	<b>Tx&gt; STAT ?</b> <b>Rx&gt; discharge</b> <b>Tx&gt; STAT:CHAR</b> <b>Tx&gt; STAT ?</b> <b>Rx&gt; charge</b> <b>Tx&gt; STAT:CHAR</b>
<b>Query Syntax</b>	none
<b>Query Response</b>	none
<b>Constraints</b>	none

**:DISCharge**

<b>Command Syntax</b>	<b>STATe:DISCharge</b>
<b>Parameters</b>	none
<b>Query Syntax</b>	none
<b>Constraints</b>	none

## 7.11 TIMER Subsystem

The TIMER subsystem sets charge timer and sample timer.

Figure 7-7  
TIMER  
Command Tree

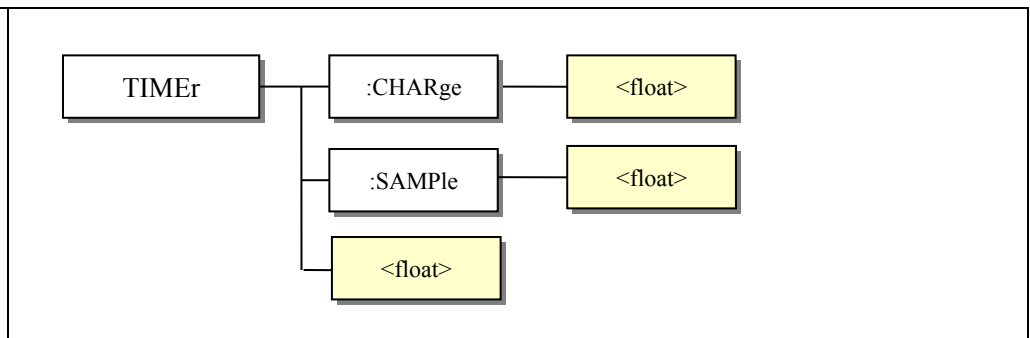

**:CHARge**

The **:CHARge** command sets charge timer value.

<b>Command Syntax</b>	<b>TIMER:CHARge &lt;float&gt;</b>
<b>Parameters</b>	<float> fix float or floating point,0-999.9
<i>For example :</i>	<b>Tx&gt; TIME:CHAR 100.1 //100.1s</b> <b>Rx&gt; TIME 0 //The charge timer sets to OFF</b>
<b>Query Syntax</b>	<b>TIMER?</b>

	<b>TIMEr:CHAR?</b>
<b>Query Response</b>	<float> 0.0-999.9
<i>For example :</i>	<b>Tx&gt;</b> TIME? //Or TIME:CHAR? <b>Rx&gt;</b> 12.0
<b>Constraints</b>	Available under DISCH state

**:SAMPle**

The :SAMPle command sets sample timer value.

<b>Command Syntax</b>	<b>TIMEr:SAMPle &lt;float&gt;</b>
<b>Parameters</b>	<float> fix float or floating point,0-999.9
<i>For example :</i>	<b>Tx&gt;</b> TIME:SAMP 100.1 <b>Tx&gt;</b> TIME:SAMP 0 //The sample timer sets to OFF
<b>Query Syntax</b>	<b>TIMEr:SAMP?</b>
<b>Query Response</b>	<float> 0.0-999.9
<i>For example :</i>	<b>Tx&gt;</b> TIME:SAMP? <b>Rx&gt;</b> 12.0
<b>Constraints</b>	Available under DISCH state

## 7.12 APERTure Subsystem

Figure 7-8  
APERTure  
Command True

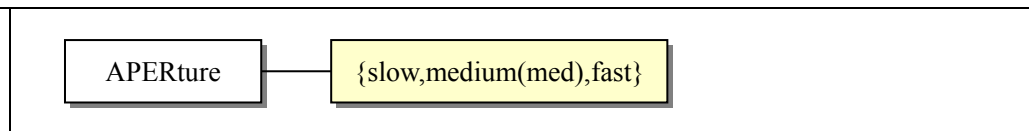

The APERTure subsystem sets the convert time of the ADC.

<b>Command Syntax</b>	<b>APERTure {slow,medium(med),fast}</b>
<b>Parameters</b>	{slow,medium(med),fast}
<i>For example :</i>	<b>Tx&gt;</b> APER fast
<b>Query Syntax</b>	<b>APERTure?</b>
<b>Query Response</b>	{slow,medium,fast}
<i>For example :</i>	<b>Tx&gt;</b> APER? <b>Rx&gt;</b> fast
<b>Constraints</b>	none

## 7.13 SYSTEM Subsystem

The SYSTEM subsystem sets KEYLOCK to ON/OFF.

Figure7-9  
SYSTEM

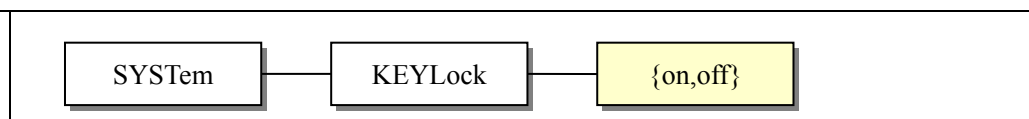

**:KEYLock**

**Command Syntax** **SYSTem:KEYLock {on(1),off(0)}**

**Parameters** {on(1),off(0)}  
 on: keypad locked.  
 off: keypad unlocked.

*For example :* **Tx>** SYST:KEYL on

**Query Syntax** **SYSTem:KEYLock?**

**Query Response** {on,off}

*For example :* **Tx>** SYST:KEYL?  
**Rx>** off

**Constraints** none

## 7.14 TRIGger Subsystem

The **TRIGger** subsystem command group is used to enable a measurement and to set the trigger mode.

Figure 2-10  
 TRIGger  
 Command Tree

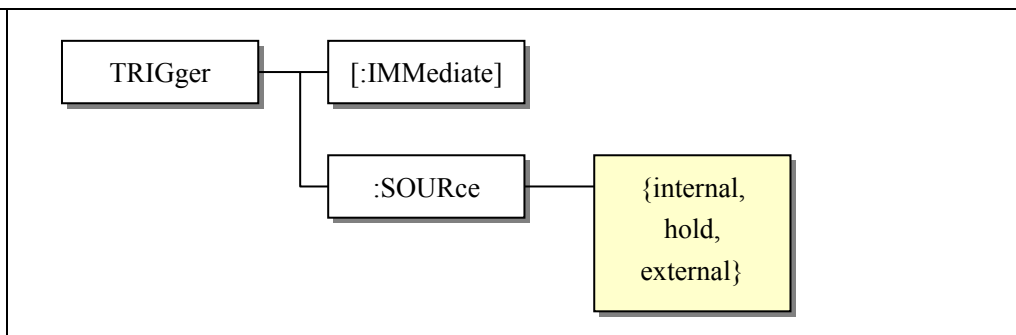

**[:IMMediate]**

The [:IMMediate] command causes the trigger to execute a measurement.

**Command Syntax** **TRIGger[:IMMediate]**

**Parameters** none

*For example :* **Tx>** TRIG:IMM  
**Tx>** TRIG

**Query Syntax** none

**Constraints** Available under DISCH state and Trigger source was HOLD.

**:SOURce**

The :SOURce command sets the trigger mode.

**Command Syntax** **TRIGger:SOURce {internal(int),hold,external(ext)}**

<b>Parameters</b>	{internal(int),hold,external(ext)}
<i>For example :</i>	<b>Tx&gt;</b> TRIG:SOUR hold
<b>Query Syntax</b>	<b>TRIGger:SOURce?</b>
<b>Query Response</b>	{internal,hold,external}
<i>For example :</i>	<b>Tx&gt;</b> TRIG:SOUR? <b>Rx&gt;</b> external
<b>Constraints</b>	Available under DISCH state

## 7.15 FETCh Subsystem

The FETCh? subsystem command group is a sensor-only command which retrieves the measurement data taken by measurement(s) initiated by a trigger

Figure 2-11  
FETCh?  
Command Tree

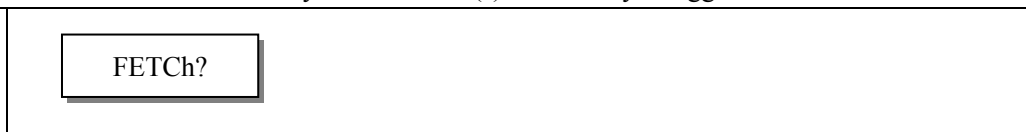

### FETCh?

<b>Query Syntax</b>	<b>FETCh?</b>
<b>Query Response</b>	<float>, <float>, {GD,NG} <float> floating point Rx <float> floating point Ix {GD,NG} comparator result
<i>For example :</i>	<b>Tx&gt;</b> FETCh? <b>Rx&gt;</b> 1.008860e+09, 9.912178e-08, GD
<b>Constraints</b>	Available under TEST state

## 7.16 ERRor Subsystem

The ERRor subsystem sets or retrieves last error information.

Figure 7-12  
ERRor?  
Command Tree



### ERRor?

<b>Query Syntax</b>	<b>ERRor?</b>
<b>Query Response</b>	no error. Error information refer to appendix B
<i>For example :</i>	<b>Tx&gt;</b> ERR? <b>Rx&gt;</b> no error

**Constraints** none

## 7.17 \*IDN? Common Command

The \*IDN? query returns AT68x Version.

Figure 7-13

\*IDN?

Common Command



**Query Syntax** \*IDN?

**Query Response** <model>, <version>, <ID>

*For example :* **Tx>** \*IDN?

**Rx>** AT680, V1.00, 68000710008

## 7.18 \*RST Common Command

\*RST restarts instrument.

Figure 2-15

\*RST

Common Command



**Command Syntax** \*RST

**Parameters** none

*For example :* **Tx>** \*RST

**Rx>** Wait for 3s...

**Query Syntax** none

**Constraints** none



# A Specifications



This chapter describes the specifications and supplemental performance characteristics of the AT680.

- Specifications
- Dimension
- Size

## AT680 Leakage Current/IR Meter Specifications

Accuracy is defined as meeting all of the following conditions.

Temperature:  $23^{\circ}\text{C} \pm 5^{\circ}\text{C}$

Humidity:  $\leq 65\%$  R.H.

Zeroing: Open Correction

Warm up time is 60 min or more.

A 1-year calibration cycle

Rate: Fast: 55 readings/s

Medium: 25 readings/s

Slow: 3 readings/s

Voltage Accuracy:  $\pm 0.5\%$

Leakage Current :

Range	Fast		Medium		Slow	
	Accuracy	Max	Accuracy	Max	Accuracy	Max
1	$5\% \pm 5$	19.9mA	$3\% \pm 5$	19.9mA	$1\% \pm 3$	19.99mA
2	$5\% \pm 5$	1.99mA	$3\% \pm 5$	1.99mA	$1\% \pm 3$	1.999mA
3	$5\% \pm 5$	199 $\mu\text{A}$	$3\% \pm 5$	199 $\mu\text{A}$	$1\% \pm 3$	1999 $\mu\text{A}$
4	$5\% \pm 5$	19.9 $\mu\text{A}$	$3\% \pm 5$	19.9 $\mu\text{A}$	$1\% \pm 3$	19.99 $\mu\text{A}$
5	$5\% \pm 5$	1.99 $\mu\text{A}$	$3\% \pm 5$	1.99 $\mu\text{A}$	$1\% \pm 3$	1.999 $\mu\text{A}$
6	$5\% \pm 5$	199nA	$3\% \pm 5$	199nA	$1\% \pm 3$	199.9nA
7	$5\% \pm 10$	19.9nA	$3\% \pm 10$	19.9nA	$1\% \pm 5$	19.99nA

Insulation Resistance : Accuracy <1G: ±1% ≥1G: ±3% ≥10G: ±5%

M=10<sup>6</sup>,G=10<sup>9</sup>

Range voltage	1	2	3	4	5	6	7
1V	---	---	5k-50k	50k-500k	500k-5M	5M-50M	50M-500M
10V	---	5k-50k	50k-500k	500k-5M	5M-50M	50M-500M	500M-5G
25V	1.25k-12.5k	12.5k-125k	125k-1.25M	1.25M-12.5M	12.5M-125M	125M-1.25G	1.25G-12.5G
50V	2.5k-25k	25k-250k	250k-2.5M	2.5M-25M	25M-250M	250M-2.5G	2.5G-25G
75V	3.75k-37.5k	37.5k-375k	375k-3.75M	3.75M-37.5M	37.5M-375M	375M-3.75G	3.75G-37.5G
100V	5k-50k	50k-500k	500k-5M	5M-50M	50M-500M	500M-5G	5G-50G
125V	6.25k-62.5k	62.5k-625k	625k-6.25M	6.25M-62.5M	62.5M-625M	625M-6.25G	625M-62.5G
250V	12.5k-125k	125k-1.25M	1.25M-12.5M	12.5M-125M	125M-1.25G	1.25G-12.5G	12.5G-125G
500V	25k-250k	250k-2.5M	2.5M-25M	25M-250M	250M-2.5G	2.5G-25G	25G-250G
650V	32.5k-325k	325k-3.25M	3.25M-32.5M	32.5M-325M	325M-3.25G	3.25G-32.5G	32.5G-325G

Display: Vacuum-Fluorescent-Display (4-Colors VFD) Size: 98x55mm  
 Output Voltage: -1.0VDC ~ -650VDC  
 Voltage Accuracy: ±0.5%  
 Parameter: Insulation Resistance, Leakage Current, Peak and Comparator Result.  
 Measurement Range: Leakage Current: 1nA~20mA  
 Resistance: 1kΩ ~ 325GΩ  
 Basic Accuracy: (@Slow Rate): Current: ±0.5%  
 Resistance: <10G: ±3% ≥10G: ±5% ≥100G: ±10%  
 Maximum counts: Slow: 3 readings/second with 9,999 counts  
 Medium: 25 readings/second with 1,999 counts  
 Fast: 55 readings/second with 1,999 counts  
 Max Charge Current: 200mA ± 20mA  
 Rate: Fast: 55 readings/s, Medium: 25 readings/s, Slow: 3 readings/s  
 Charge Time: 999.9s 0.1s resolution Accuracy: ±0.5%  
 Sample Time: 999.9s 0.1s resolution Accuracy: ±0.5%  
 Trigger: Internal, Manual (Remote) and External Trigger  
 Range: Auto and Manual  
 Correction: Open Clear Zero  
 Comparator: 30 sets of record. Display and Output GD/GD.  
 Beep: GD, NG and OFF  
 Interfaces: Built-in Handler Interface.  
 Built-in RS232C Interface.  
 Program Language: SCPI  
 Environmental: 18°C~28°C stated accuracy ≤ 65% RH  
 Operating: 10°C~40°C stated accuracy 10~80% RH  
 Storage: 0°C~50°C stated accuracy 10~90% RH

Power:	100V ~ 120VAC	48.5Hz ~ 52.5Hz
Fuse:	250V 1A Slow blow	50VA maximum
Weight:	Approximately 5kg	(NET)
	Approximately 6kg	(SHIPPING)
Accessories:	User's Manual	
	ATL680 Lead Set	
	AC Power Cable	
	Warranty Certificate	

## Dimensions

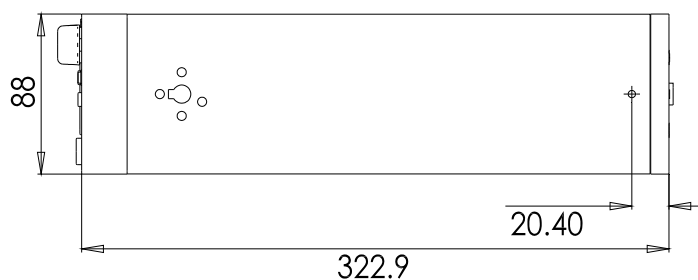
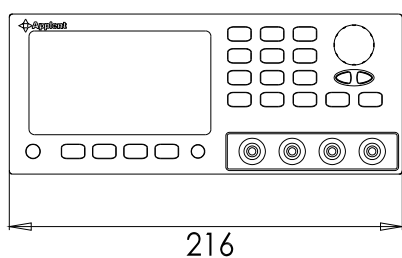
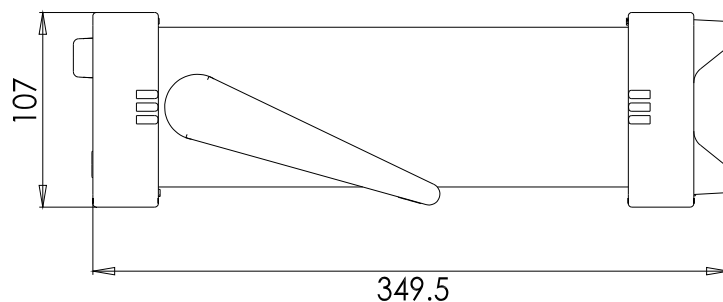
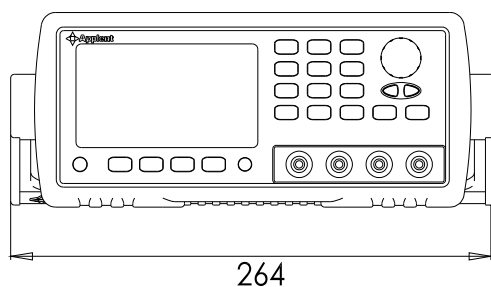

-AT680 Leakage Current/IR Meter User's Manual-

<http://www.applent.com>

©2005-2009 All rights are reserved. Applent Instruments Inc.